

# TITAN

---

## S E R I E S



(model shown) #  
T12-BC-4884-OP

## Core Systems

The complete versatility of the Titan system will handle a multitude of functions in the laboratory environment. From research facilities to teaching labs, there is a configuration to meet your requirements. The island core design is extremely versatile and durable to exceed your laboratory needs. The core has slotted uprights for shelving, table frames, and cabinet options.

so adaptable.

- Titan Core System configurations can be readily created and easily changed as well as moved for new applications or changing space.
- Can be used in conjunction with suspended, mobile or floor-mounted casework.
- Solid durable construction
- Includes a fine adjust leveling foot
- Static capacity of 2600lbs (on a double sided, four shelves, two table frame unit) SEFA tested
- Cantilever table frames available in depths of 24" & 30"
- Available in: 24", 30", 36", 42", 48", 54", 60", 72"
- Cabinets: mobile, hanging, or floor mounted ordered separately
- Counter top options available in Phenolic & Epoxy
- Order shelving separately. There are a variety of options. Shelf brackets are adjustable in 1" increments to allow for multiple configurations. Shelf depths vary based on necessity.
- Standard shelves are 12", 14", 16", and 18" deep. Shelves can be flush to the core uprights or inset 6" between core uprights. 12" inner shelves available to work in conjunction with standard exterior shelves.

where versatility meets functionality

Air Master Systems Corp.

6480 Norton Center Drive, Muskegon, MI 49441 • 231.798.1111 • 231.798.4000 fax • [airmastersystems.com](http://airmastersystems.com)



© 2016 Air Master Systems Corp

## Ordering Guide:

### Titan Full Height Cores

#### T12 Core: 3"-6"-3"

85" High, available from 24" to 72" wide. Levelers with 1" adjustment. Floor mounted. Suitable for wall or island configurations where general services are needed.

#### T9 Core: 3"-6"

85" High, available from 24" to 72" wide. Levelers with 1" adjustment. Floor and wall mounted. Suitable for wall configuration where general services are needed.

#### T3 Core: 3"

85" High, available from 24" to 72" wide. Levelers with 1" adjustment, Lower Removable Panels optional

**For wall configuration:** Floor and wall mounted when used with cantilever tables, not necessary when used with base cabinets or structural cantilever table frames

**For island configurations:** used only with base units or structural table frames

#### Gauges

Post: 14 gauge	T12, T9, T3
Inserts: 18 gauge	T12, T9
Horizontal supports: 14 gauge	T12, T9, T3
Floor Bracket: 10 gauge	T12, T9, T3
Shelves: 16 gauge	T12, T9, T3

**Inserts:** T12 & T9, ordered separately lower removable Panels, side covers

**Shelves:** Ordered separately adjustable in 1" increments max load: 200 lbs per shelf (SEFA) T12, T9, T3

**Cantilever table:** ordered separately adjustable in 1" increments for 24" or 30" counter top max load: 800lbs (SEFA) T12, T9, T3

**Structural Cantilever table:** ordered separately adjustable in 1" increments for 24" or 30" counter top T12, T9, T3

Hanging Cabinets: ordered separately and to be used with cantilever tables. 25" high available T12, T9, T3 example: SHB-2536

#### T12-BC-4884-0N

(model as shown)

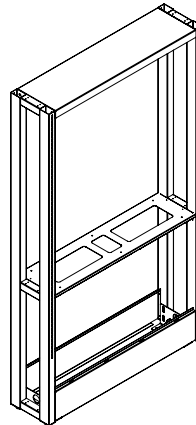

#### T12-BC-4884-2E

(model as shown)

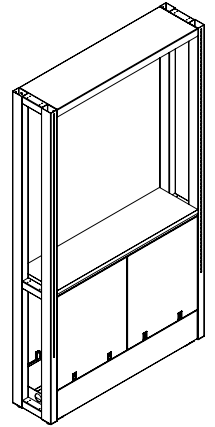

#### T9-BC-4884-0N

(model as shown)

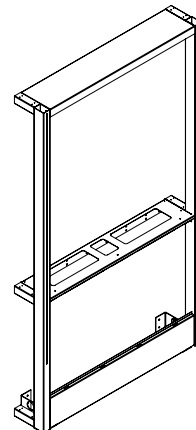

#### T9-BC-4884-1N

(model as shown)

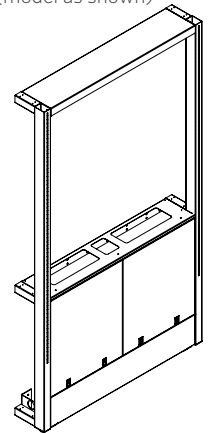

#### T3-IPBC-4884-0N

(model as shown)

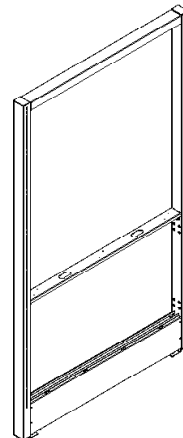

#### T3-WPBC-4884-1N

(model as shown)

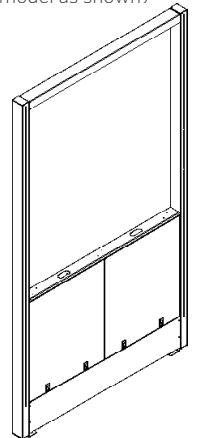

Air Master Systems Corp.

6480 Norton Center Drive, Muskegon, MI 49441 • 231.798.1111 • 231.798.4000 fax • [airmastersystems.com](http://airmastersystems.com)

## Ordering Guide:

### Lower Cores

#### T12 Core: 3"-6"-3"

Available in 47" and 35" heights available from 24" to 72" wide Levelers with 1" adjustment. Floor mounted. Suitable for wall or island configurations where general services are needed.

#### T9 Core: 3"-6"

Available in 47" and 35" heights available from 24" to 72" wide Levelers with 1" adjustment. Floor and wall mounted. Suitable for wall configuration where general services are needed.

#### Gauges

Post: 14 gauge	T12, T9,
Inserts: 18 gauge	T12, T9
Horizontal supports: 14 gauge	T12, T9,
Floor Bracket: 10 gauge	T12, T9,

**Inserts:** T12 & T9, ordered separately lower removable Panels, side covers

**Cantilever table:** ordered separately adjustable in 1" increments for 24" or 30" counter top max load: 800lbs (SEFA) T12, T9,

**Structural Cantilever table:** ordered separately adjustable in 1" increments for 24" or 30" counter top T12, T9,

Hanging Cabinets: ordered separately and to be used with cantilever tables. 25" and 31" heights available T12, T9, example: SHB-2536

## The Titan Core

#### Size:

T12: Titan 12" core  
T9: Titan 9" core  
T3: Titan 3" core

#### Top:

E Epoxy  
P Phenolic  
O Other  
N None

**T12-BC-4884-2E**

#### Style:

B: Box  
C: Core  
I: Island  
P: Panel  
R: Reagent

Width inches:    Height inches:

Panels:  
0: no panels  
1: one panel  
2: two panels

#### T12-RLC-4847-ON

(model as shown)

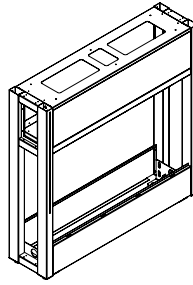

#### T12-RLC-4847-2E

(model as shown)

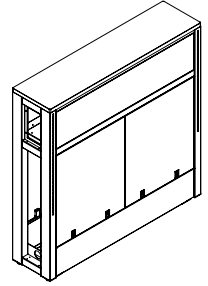

#### T12-LC-4835-ON

(model as shown)

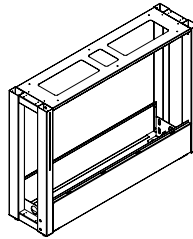

#### T12-LC-4835-2E

(model as shown)

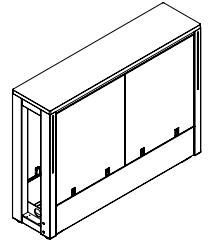

#### T9-LC-4835-ON

(model as shown)

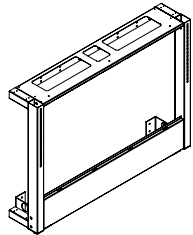

#### T9-LC-4835-1N

(model as shown)

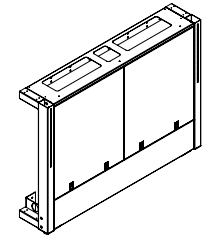

#### T9-RLC-4847-ON

(model as shown)

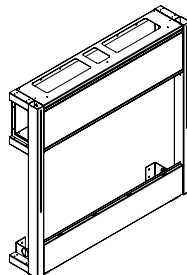

#### T9-RLC-4847-1N

(model as shown)

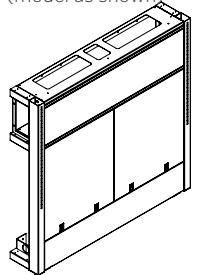

Air Master Systems Corp.

6480 Norton Center Drive, Muskegon, MI 49441 • 231.798.1111 • 231.798.4000 fax • [airmastersystems.com](http://airmastersystems.com)

© 2016 Air Master Systems Corp

# Ordering Guide:

Shelf Kit System:

## TSK-1848-12B

Depth-Bracket Depth:

- 18"-12"
- 20"-14"
- 22"-16"
- 24"-18"

Island Core Width:

24", 30", 36", 42", 48", 54", 60", 66", 72"

## TSK-1248-12B

Depth-Bracket Depth:

- 12"-12"
- 14"-14"
- 16"-16"
- 18"-18"

Island Core Width:

24", 30", 36", 42", 48", 54", 60", 66", 72"

## TSK-1848-12i

Depth-Bracket Depth:

- 12"-12"
- (only)

Island Core Width:

24", 30", 36", 42", 48", 54", 60", 66", 72"

## TSK-1848-12B

(model as shown)

## TSK-1248-12B

(model as shown)

## TSK-1248-12i

(model as shown)

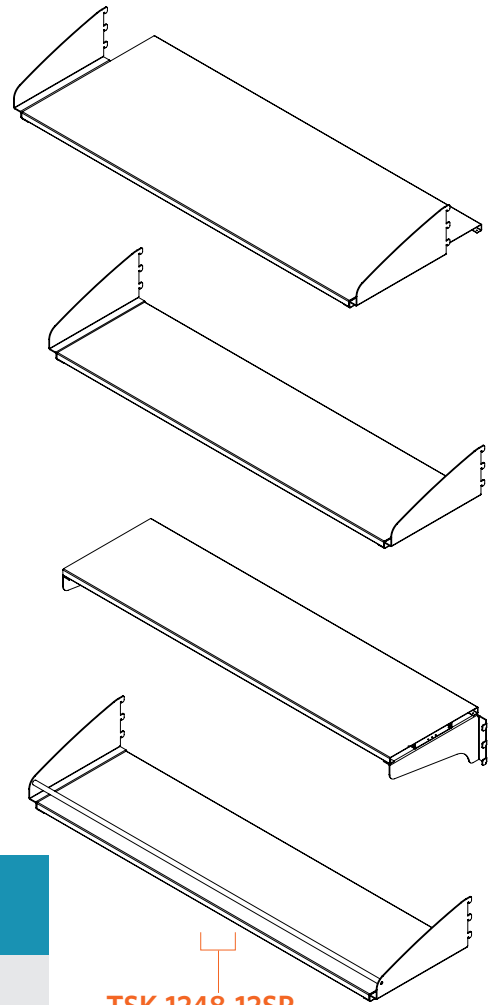

## TSK-1248-12SR

Seismic Rod/Width  
(available for all shelves)

### Titan Shelf Kit

Style:

- T Titan
- S Shelf
- K Kit

Top:

- B Bracket
- I Inside Bracket
- S Seismic Rod  
(includes brackets)

## TSK-1848-12B

Depth inches:    Width inches:    Bracket Depth

### Removable Panels

Style:

- T Titan
- S Side
- K Removable
- P Panel

Top:

- B Box
- C Core

## TSRP-U-BC

upper  
lower  
middle

## TSRP-U-BC

(model as shown)

## TSRP-M

(model as shown)

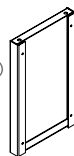

## TSRP-L

(model as shown)

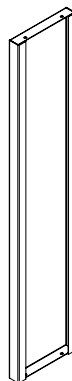

## TSRP-U-RBC

(model as shown)

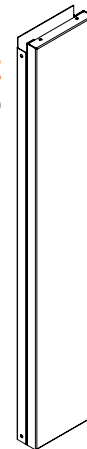

Air Master Systems Corp.

6480 Norton Center Drive, Muskegon, MI 49441 • 231.798.1111 • 231.798.4000 fax • [airmastersystems.com](http://airmastersystems.com)

## Ordering Guide:

### Cantilever Table frame

**TitanTable Frame** are the basic component setting a titan configuration in your lab. The frame construction is 14 gauge steel. It has widths of 24" to 72" in 6" increments. The Titan also has capabilities to mount hanging cabinets.

**Table Frames Free Standing** gives the maximum flexibility for configuring your lab. These tables are 30" and 36" deep. They can be fixed or adjustable in height. In this model you can have leveling feet or casters installed. The table will support up to 1,000lbs.

**Cantilevered Tables** attach directly to the core, the core should be bolted to the floor. They can support hanging cabinets or mobile units under the frame. Height adjustable in one inch increments. Depth available 24" to 30" deep. The table will support up to 800lbs.

**Structural Support Table Frames** attach directly to the core. They support the Island or Wall cores when the cores cannot be bolted to the floor. The table has a fixed height of 30" or 35". The table will support up to 800lbs.

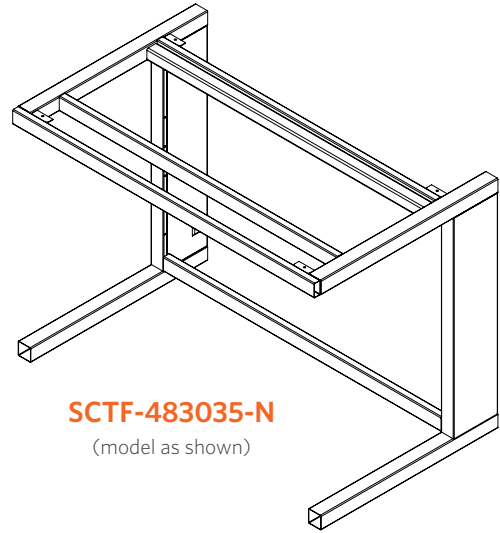

**SCTF-483035-N**  
(model as shown)

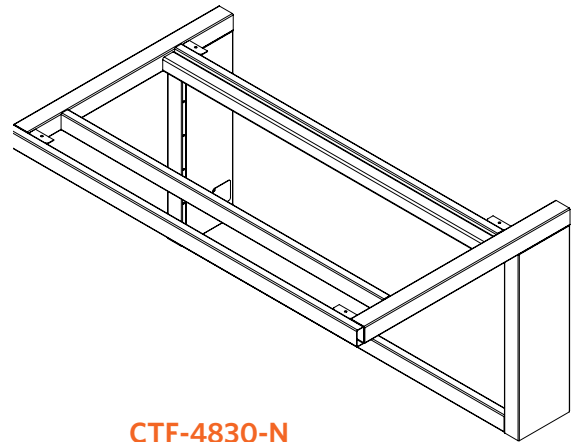

**CTF-4830-N**  
(model as shown)

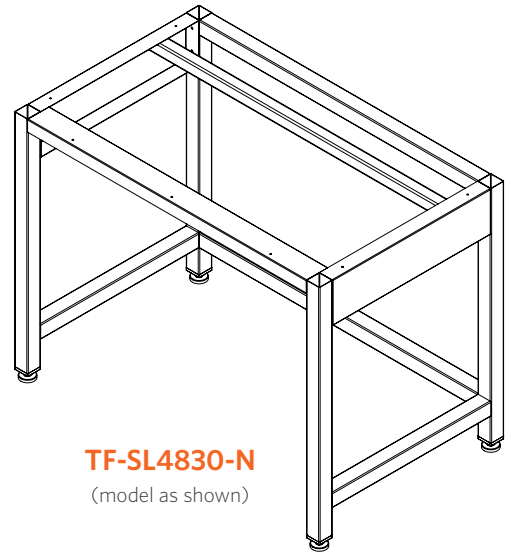

**TF-SL4830-N**  
(model as shown)

### Cantilever Table Frame

**Style:**

- T Table
- S Structural
- F Frame
- C Cantilever

**Top:**

- E Epoxy
- P Phenolic
- O Other
- N None

**SCTF-483035-E**

Width inches:    Depth inches:    Height inches:

Air Master Systems Corp.

6480 Norton Center Drive, Muskegon, MI 49441 • 231.798.1111 • 231.798.4000 fax • [airmastersystems.com](http://airmastersystems.com)