



## Solution Table

The complete flexibility of the Solution Series™ Table will handle a multitude of functions in the laboratory environment. From clean rooms and research facilities to teaching labs, there is a configuration to meet your needs. The Solution Table is available in a multitude of sizes and can be ordered in stationary, adjustable height and knock down versions.

Model # **ST-AL4830-E**  
See reverse for ordering guide.

so adaptable.

- Wall and island configurations can be readily created and easily changed as well as moved for new applications or changing space
- Can be used in conjunction with mobile or floor-mounted casework
- Solid welded construction
- Stationary models include a fine-adjust leveling foot
- Can be ordered as mobile models with 330 lb. casters
- Static load capacity of 1000 lbs. (on stationary models)
- Standard working height is 36"
- Adjustable height from 30-36"
- Available in 36, 48, 60 and 72" widths
- Available in 24, 30 and 36" depths
- Cabinets ordered separately
- Counter top options available
- Adjustable height models include a leg lock-down bolt and adjust in 1" increments

Air Master Systems Corp.

6480 Norton Center Drive, Muskegon, MI 49441 • 231.798.1111 • 231.798.4000 fax • [airmastersystems.com](http://airmastersystems.com)



# Ordering Guide

## Solution Table

**Legs:**

- A Adjustable
- S Stationary
- K Knock down

**Feet:**

- L Leveling Feet
- C 330 lb. Casters

ST - AL4830 - E

**Width:**

36"  
48"  
60"  
72"

**Depth:**

24"  
30"  
36"

**Top:**

E Epoxy  
P Phenolic  
O Other  
N None

**Note:** Knock down models are not available with casters and have a 5.5" apron on three sides and an ADA accessible front.

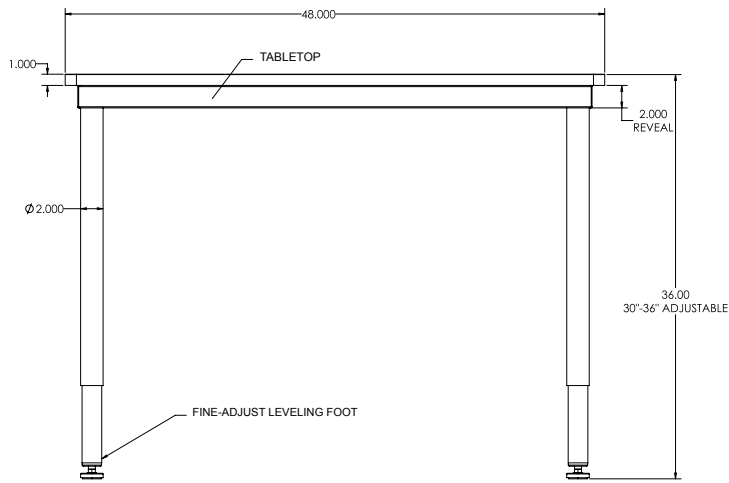

SOLUTION TABLE FRONT VIEW:

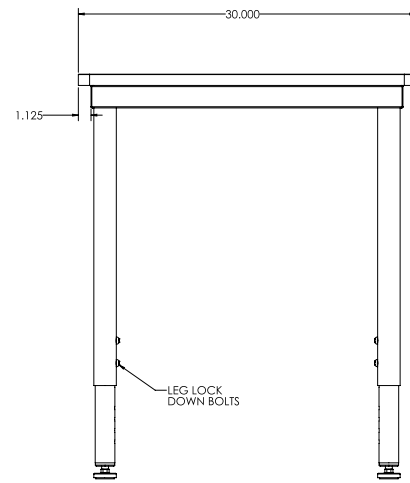

SOLUTION TABLE END VIEW:

## ST-AL4830-E

(model as shown)



**Air Master Systems Corp.**

6480 Norton Center Drive, Muskegon, MI 49441 • 231.798.1111 • 231.798.4000 fax • [airmastersystems.com](http://airmastersystems.com)